

Typical Swale Cross Section

- Notes:**
- The bottoms of seeded, grass-lined channels with grades from 1% to 2% shall have erosion control blankets properly installed.
 - Channels with grades greater than 2% and up to 6% shall have bottoms lined in staked sod.
 - All channels with grades greater than 6% shall have bottoms lined with 6" rip-rap.
 - Side banks of grass-lined channels with a grade to 2% of greater shall be protected by erosion control blankets installed coincidental with seeding, and in accordance with manufacturer's recommendations.
 - There are other erosion control methods available. If the contractor wishes to use such methods and products, the Vanderburgh County Surveyor will need to approve such methods and products prior to installation.

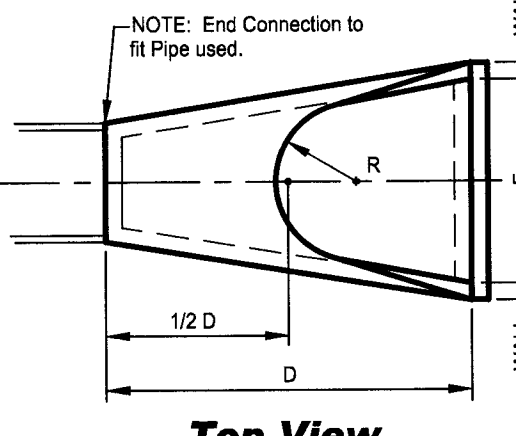

Top View

LINE NO.	WALL	A	B	C	D	E	G	R	SLOPE
101	5.50	2.14	8'	2.34	4.12	6.34	1.11	2.14	2:1
102	6.00	2.14	8'	2.34	4.12	6.34	1.11	2.14	2:1
103	6.50	2.14	8'	2.34	4.12	6.34	1.11	2.14	2:1
104	7.00	2.14	8'	2.34	4.12	6.34	1.11	2.14	2:1
105	7.50	2.14	8'	2.34	4.12	6.34	1.11	2.14	2:1
106	8.00	2.14	8'	2.34	4.12	6.34	1.11	2.14	2:1
107	8.50	2.14	8'	2.34	4.12	6.34	1.11	2.14	2:1
108	9.00	2.14	8'	2.34	4.12	6.34	1.11	2.14	2:1
109	9.50	2.14	8'	2.34	4.12	6.34	1.11	2.14	2:1
110	10.00	2.14	8'	2.34	4.12	6.34	1.11	2.14	2:1
111	10.50	2.14	8'	2.34	4.12	6.34	1.11	2.14	2:1
112	11.00	2.14	8'	2.34	4.12	6.34	1.11	2.14	2:1
113	11.50	2.14	8'	2.34	4.12	6.34	1.11	2.14	2:1
114	12.00	2.14	8'	2.34	4.12	6.34	1.11	2.14	2:1
115	12.50	2.14	8'	2.34	4.12	6.34	1.11	2.14	2:1
116	13.00	2.14	8'	2.34	4.12	6.34	1.11	2.14	2:1
117	13.50	2.14	8'	2.34	4.12	6.34	1.11	2.14	2:1
118	14.00	2.14	8'	2.34	4.12	6.34	1.11	2.14	2:1
119	14.50	2.14	8'	2.34	4.12	6.34	1.11	2.14	2:1
120	15.00	2.14	8'	2.34	4.12	6.34	1.11	2.14	2:1
121	15.50	2.14	8'	2.34	4.12	6.34	1.11	2.14	2:1
122	16.00	2.14	8'	2.34	4.12	6.34	1.11	2.14	2:1
123	16.50	2.14	8'	2.34	4.12	6.34	1.11	2.14	2:1
124	17.00	2.14	8'	2.34	4.12	6.34	1.11	2.14	2:1
125	17.50	2.14	8'	2.34	4.12	6.34	1.11	2.14	2:1
126	18.00	2.14	8'	2.34	4.12	6.34	1.11	2.14	2:1
127	18.50	2.14	8'	2.34	4.12	6.34	1.11	2.14	2:1
128	19.00	2.14	8'	2.34	4.12	6.34	1.11	2.14	2:1
129	19.50	2.14	8'	2.34	4.12	6.34	1.11	2.14	2:1
130	20.00	2.14	8'	2.34	4.12	6.34	1.11	2.14	2:1
131	20.50	2.14	8'	2.34	4.12	6.34	1.11	2.14	2:1
132	21.00	2.14	8'	2.34	4.12	6.34	1.11	2.14	2:1
133	21.50	2.14	8'	2.34	4.12	6.34	1.11	2.14	2:1
134	22.00	2.14	8'	2.34	4.12	6.34	1.11	2.14	2:1
135	22.50	2.14	8'	2.34	4.12	6.34	1.11	2.14	2:1
136	23.00	2.14	8'	2.34	4.12	6.34	1.11	2.14	2:1
137	23.50	2.14	8'	2.34	4.12	6.34	1.11	2.14	2:1
138	24.00	2.14	8'	2.34	4.12	6.34	1.11	2.14	2:1
139	24.50	2.14	8'	2.34	4.12	6.34	1.11	2.14	2:1
140	25.00	2.14	8'	2.34	4.12	6.34	1.11	2.14	2:1
141	25.50	2.14	8'	2.34	4.12	6.34	1.11	2.14	2:1
142	26.00	2.14	8'	2.34	4.12	6.34	1.11	2.14	2:1
143	26.50	2.14	8'	2.34	4.12	6.34	1.11	2.14	2:1
144	27.00	2.14	8'	2.34	4.12	6.34	1.11	2.14	2:1
145	27.50	2.14	8'	2.34	4.12	6.34	1.11	2.14	2:1
146	28.00	2.14	8'	2.34	4.12	6.34	1.11	2.14	2:1
147	28.50	2.14	8'	2.34	4.12	6.34	1.11	2.14	2:1
148	29.00	2.14	8'	2.34	4.12	6.34	1.11	2.14	2:1
149	29.50	2.14	8'	2.34	4.12	6.34	1.11	2.14	2:1
150	30.00	2.14	8'	2.34	4.12	6.34	1.11	2.14	2:1
151	30.50	2.14	8'	2.34	4.12	6.34	1.11	2.14	2:1
152	31.00	2.14	8'	2.34	4.12	6.34	1.11	2.14	2:1
153	31.50	2.14	8'	2.34	4.12	6.34	1.11	2.14	2:1
154	32.00	2.14	8'	2.34	4.12	6.34	1.11	2.14	2:1
155	32.50	2.14	8'	2.34	4.12	6.34	1.11	2.14	2:1
156	33.00	2.14	8'	2.34	4.12	6.34	1.11	2.14	2:1
157	33.50	2.14	8'	2.34	4.12	6.34	1.11	2.14	2:1
158	34.00	2.14	8'	2.34	4.12	6.34	1.11	2.14	2:1
159	34.50	2.14	8'	2.34	4.12	6.34	1.11	2.14	2:1
160	35.00	2.14	8'	2.34	4.12	6.34	1.11	2.14	2:1
161	35.50	2.14	8'	2.34	4.12	6.34	1.11	2.14	2:1
162	36.00	2.14	8'	2.34	4.12	6.34	1.11	2.14	2:1
163	36.50	2.14	8'	2.34	4.12	6.34	1.11	2.14	2:1
164	37.00	2.14	8'	2.34	4.12	6.34	1.11	2.14	2:1
165	37.50	2.14	8'	2.34	4.12	6.34	1.11	2.14	2:1
166	38.00	2.14	8'	2.34	4.12	6.34	1.11	2.14	2:1
167	38.50	2.14	8'	2.34	4.12	6.34	1.11	2.14	2:1
168	39.00	2.14	8'	2.34	4.12	6.34	1.11	2.14	2:1
169	39.50	2.14	8'	2.34	4.12	6.34	1.11	2.14	2:1
170	40.00	2.14	8'	2.34	4.12	6.34	1.11	2.14	2:1
171	40.50	2.14	8'	2.34	4.12	6.34	1.11	2.14	2:1
172	41.00	2.14	8'	2.34	4.12	6.34	1.11	2.14	2:1
173	41.50	2.14	8'	2.34	4.12	6.34	1.11	2.14	2:1
174	42.00	2.14	8'	2.34	4.12	6.34	1.11	2.14	2:1
175	42.50	2.14	8'	2.34	4.12	6.34	1.11	2.14	2:1
176	43.00	2.14	8'	2.34	4.12	6.34	1.11	2.14	2:1
177	43.50	2.14	8'	2.34	4.12	6.34	1.11	2.14	2:1
178	44.00	2.14	8'	2.34	4.12	6.34	1.11	2.14	2:1
179	44.50	2.14	8'	2.34	4.12	6.34	1.11	2.14	2:1
180	45.00	2.14	8'	2.34	4.12	6.34	1.11	2.14	2:1
181	45.50	2.14	8'	2.34	4.12	6.34	1.11	2.14	2:1
182	46.00	2.14	8'	2.34	4.12	6.34	1.11	2.14	2:1
183	46.50	2.14	8'	2.34	4.12	6.34	1.11	2.14	2:1
184	47.00	2.14	8'	2.34	4.12	6.34	1.11	2.14	2:1
185	47.50	2.14	8'	2.34	4.12	6.34	1.11	2.14	2:1
186	48.00	2.14	8'	2.34	4.12	6.34	1.11	2.14	2:1
187	48.50	2.14	8'	2.34	4.12	6.34	1.11	2.14	2:1
188	49.00	2.14	8'	2.34	4.12	6.34	1.11	2.14	2:1
189	49.50	2.14	8'	2.34	4.12	6.34	1.11	2.14	2:1
190	50.00	2.14	8'	2.34	4.12	6.34	1.11	2.14	2:1
191	50.50	2.14	8'	2.34	4.12	6.34	1.11	2.14	2:1
192	51.00	2.14	8'	2.34	4.12	6.34	1.11	2.14	2:1
193	51.50	2.14	8'	2.34	4.12	6.34	1.11	2.14	2:1
194	52.00	2.14	8'	2.34	4.12	6.34	1.11	2.14	2:1
195	52.50	2.14	8'	2.34	4.12	6.34	1.11	2.14	2:1
196	53.00	2.14	8'	2.34	4.12	6.34	1.11	2.14	2:1
197	53.50	2.14	8'	2.34	4.12	6.34	1.11	2.14	2:1
198	54.00	2.14	8'	2.34	4.12	6.34	1.11	2.14	2:1
199	54.50	2.14	8'	2.34	4.12	6.34	1.11	2.14	2:1
200	55.00	2.14	8'	2.34	4.12	6.34	1.11	2.14	2:1
201	55.50	2.14	8'	2.34	4.12	6.34	1.11	2.14	2:1
202	56.00	2.14	8'	2.34	4.12	6.34	1.11	2.14	2:1
203	56.50	2.14	8'	2.34	4.12	6.34	1.11	2.14	2:1
204	57.00	2.14	8'	2.34	4.12	6.34	1.11	2.14	2:1
205	57.50	2.14	8'	2.34	4.12	6.34	1.11	2.14	2:1
206	58.00	2.14	8'	2.34	4.12	6.34	1.11	2.14	2:1
207	58.50	2.14	8'	2.34	4.12	6.34	1.11	2.14	2:1
208	59.00	2.14	8'	2.34	4.12	6.34	1.11	2.14	2:1
209	59.50	2.14	8'	2.34	4.12	6.34	1.11	2.14	2:1
210	60.00	2.14	8'	2.34	4.12	6.34	1.11	2.14	2:1
211	60.50	2.14	8'	2.34	4.12	6.34	1.11	2.14	2:1
212	61.00	2.14	8'	2.34	4.12	6.34	1.11	2.14	2:1
213	61.50	2.14	8'	2.34	4.12	6.34	1.11	2.14	2:1
214	62.00	2.14	8'	2.34	4.12	6.34	1.11	2.14	2:1
215	62.50	2.14	8'	2.34	4.12	6.34	1.11	2.14	2:1
216	63.00	2.14	8'	2.34	4.12	6.34	1.11	2.14	2:1
217	63.50	2.14	8'	2.34	4.12	6.34	1.11	2.14	2:1
218	64.00	2.14	8'	2.34	4.12	6.34	1.11	2.14	2:1
219	64.50	2.14	8'	2.34	4.12	6.34	1.11	2.14	2:1
220	65.00	2.14	8'	2.34	4.12	6.34	1.11	2.14	2:1
221	65.50	2.14	8'	2.34	4.12	6.34	1.11	2.14	2:1
222	66.00	2.14	8'	2.34	4.12	6.34	1.11	2.14	2:1
223	66.50	2.14	8'	2.34	4.12	6.34	1.11	2.14	2:1
224	67.00	2.14	8'	2.34	4.12	6.34	1.11	2.14	2:1
225	67.50	2.14	8'	2.34	4.12	6.34	1.11	2.14	2:1
226	68.00	2.14	8'	2.34	4.12	6.34	1.11	2.14	2:1
227	68.50	2.14	8'	2.34	4.12	6.34	1.11	2.14	2:1
228	69.00	2.14	8'	2.34	4.12	6.34	1.11	2.14	2:1
229	69.50	2.14	8'	2.34	4.12	6.34	1.11	2.14	2:1
230	70.00	2.14	8'	2.34	4.12	6.34			